

# Inquiry form for the SKG-service lift ISO-Z

Bi-parting doors on serving height and swing doors serving at floor level according to EN81-3 and Machine Directive 2006/42/EC

See catalogue SKG „Service lifts“, pages 56 to 59

## PROJECT

Client: \_\_\_\_\_

Project: \_\_\_\_\_

Date: \_\_\_\_\_ Request: \_\_\_\_\_

## GENERAL

Capacity:  100 kg  200 kg  300 kg Safety gear:  Yes  No

Chargement:  Front-loading  Through-loading

Position of machine room:  on top  side above (Special design)  side below (Special design)

Number of stops: \_\_\_\_\_ Number of landings: \_\_\_\_\_ Floor markings: \_\_\_\_\_

Power supply:  3 x 400 V 50 Hz  3 x 380 V 50 Hz  3 x 230 V 50 Hz  1 x 220 V 50 Hz

Others: \_\_\_\_\_

### Shaft (Floor to floor distances see in supplement for floor to floor distances)

Width: \_\_\_\_\_ mm Depth: \_\_\_\_\_ mm Travel: \_\_\_\_\_ mm Headroom: \_\_\_\_\_ mm Pit: \_\_\_\_\_ mm

### Cabin

Width: \_\_\_\_\_ mm Depth: \_\_\_\_\_ mm Height: \_\_\_\_\_ mm Number of shelves: \_\_\_\_\_

## FINISHES

	Cabin	Landing doors	Machine room door
Gavanized	<input type="radio"/>	<input type="radio"/>	<input type="radio"/>
Primed painted RAL 7032	<input type="radio"/>	<input type="radio"/>	<input type="radio"/>
Stainless steel 1.4016 (AISI 430) brushed grain K240	<input type="radio"/>	<input type="radio"/>	<input type="radio"/>
Stainless steel 1.4301 (AISI 304) brushed grain K240	<input type="radio"/>	<input type="radio"/>	<input type="radio"/>
Stainless steel 1.4301 (AISI 304) 5WL	<input type="radio"/>	<input type="radio"/>	<input type="radio"/>
Stainless steel 1.4571 (AISI 316Ti) brushed grain K240	<input type="radio"/>	<input type="radio"/>	<input type="radio"/>

Other finishes: \_\_\_\_\_

RAL \_\_\_\_\_ RAL \_\_\_\_\_ RAL \_\_\_\_\_

Galvanized with powder coating, following RAL colours are available:

RAL 3000	RAL 5010	RAL 7016	RAL 7035	RAL 9005	RAL 9010	RAL 9016
----------	----------	----------	----------	----------	----------	----------

# Inquiry form for the SKG-service lift ISO-Z

Bi-parting doors on serving height and swing doors serving at floor level according to EN81-3 and Machine Directive 2006/42/EC

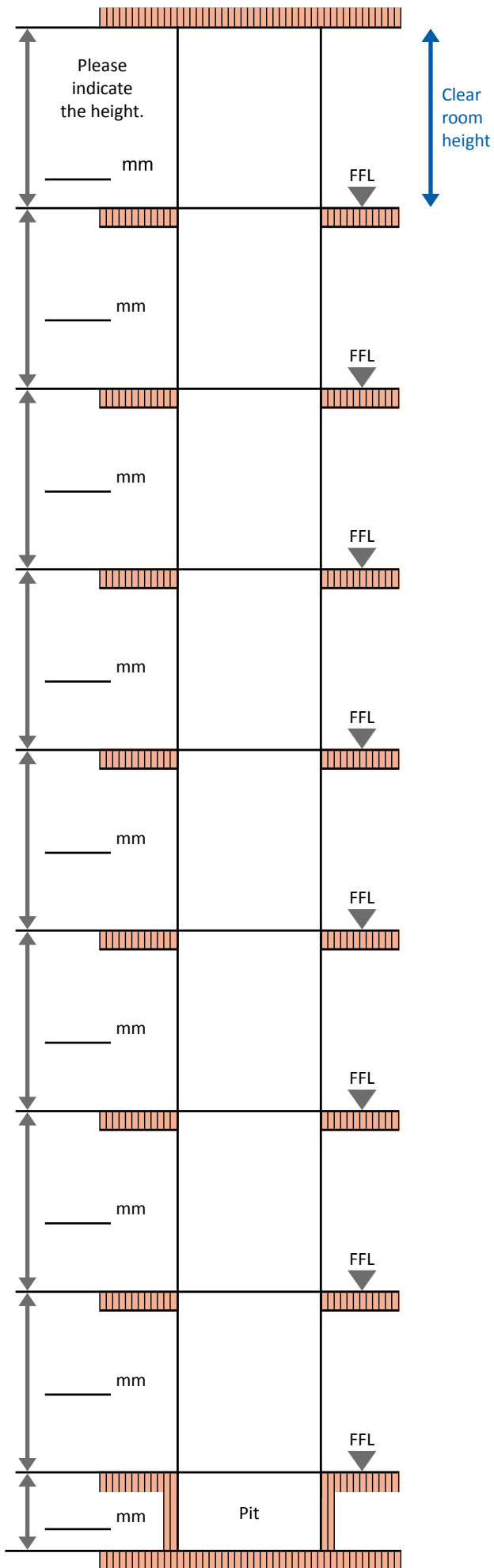

Please check the floors.

1 2 3 4 5 6 7 8

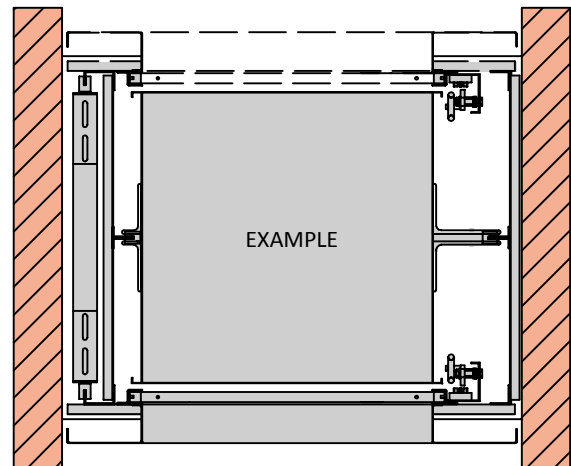

1 2 3 4 5 6 7 8

Please check the floors.

# Inquiry form for the SKG-service lift ISO-Z

Bi-parting doors on serving height and swing doors serving at floor level according to EN81-3 and Machine Directive 2006/42/EC

## OPTIONS

### Shaft

Ladder:  Yes  with anti-theft device

Lightning:  Yes  No

### Cabin

Lightning:  Yes  No

Heating:  Ceiling  Floor  Shelves, quantity: \_\_\_\_\_

Cabin protection:  Roller shutter (only the cabin above)  Drop bar  Rear guard plate  Limit strips

**Attention: Possibly, the clear cabin dimensions and / or the shaft dimensions are changing!**

### Landing doors

Double walls:  Yes  additionally with mineral wool

Fire certificate: **Not available for this type of doors!**

Safety lock:  with profile cylinder  with KABA cylinder (for Switzerland only)

### Machine room door

Double walls:  Yes  additionally with mineral wool

Fire certificate:  EN81-58 E120 EW60  EN81-58 EI60

Safety lock:  with profile cylinder  with KABA cylinder (for Switzerland only)

### Electrical:

Lockable push button stations:  with profile cylinder  with KABA cylinder (for Switzerland only)

Switching off control current (only for one push button station possible):  with profile cylinder

with KABA cylinder (for Switzerland only)

### Other equipment: